



A brand of Asco Pompe
Diaphragm Pumps

Model V2CP Plastic

AIR OPERATED DOUBLE DIAPHRAGM PUMPS

STEPPING UP WITH US

Specifications

Suction & Discharge Size:	1/4" x 1/4"
Standard Porting Location*:	End
Connection Types:	FBSP
Air Inlet & Air Exhaust Size:	1/4" FNPT x 1/4" FNPT

*Optional BSP threaded center port horizontal/vertical position.

Capabilities

Maximum Flow Rate:	26 lpm
Maximum Air Supply Pressure:	6,0 bar
Displacement per Stroke:	0,06 lit
Minimum Air Inlet Pressure:	1,2 bar
Maximum Particle Size:	1,0 mm
Sound Pressure:	68 dB(A)
Operating Temperature:	Determined by elastomers



V02 Performance

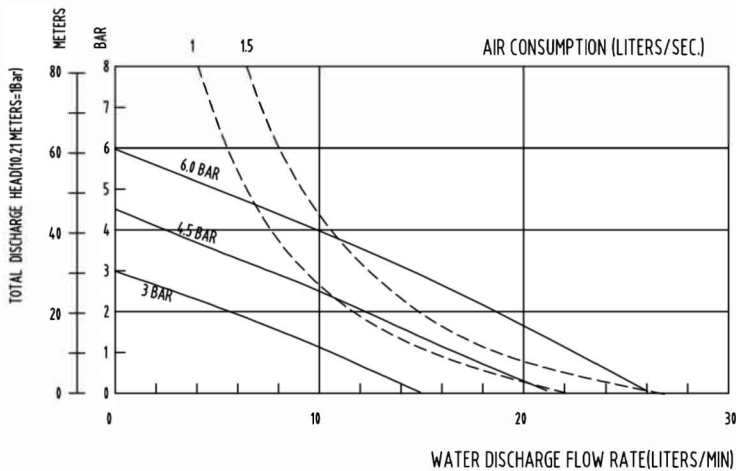

Note: Full stroke diaphragm allows performance to be equal for all elastomers.

Typical Applications

- Acids & Bases
- Plating Solutions
- Paints, Inks, Solvents
- Ceramic Glaze
- Lubricants and Oils

Typical Industries

- Paints and Coatings
- Ceramics
- Pulp and Paper
- Electroplating & Anodizing
- Marine
- Chemical Manufacturing & Distribution
- OEM's

Construction

Wetted Materials:	Polypropylene and PVDF
Diaphragm Materials:	Santoprene™, PTFE
Air Valve:	Polypropylene
Ball Materials:	Santoprene™, PTFE
Seat Materials:	Polypropylene
O-ring Materials:	NBR, PTFE

Santoprene™ is a registered tradename of Exxon Mobil Corp

STEPPING UP WITH US

Dimensions

Maximum Height:	162 mm
Maximum Width:	185 mm
Maximum Depth:	116 mm

Weight

Polypropylene / PVDF:	1,3 / 1,4kg
-----------------------	-------------

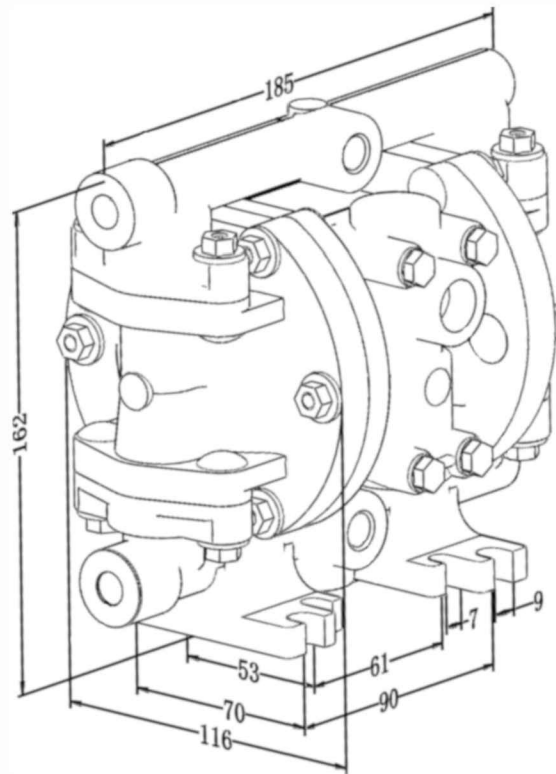

A brand of Asco Pompe
Diaphragm Pumps